

Runs two shifts on one battery charge – guaranteed

Advanced ergonomic design and key stability features provide optimum operator comfort and control

Industry-leading performance and efficiency from proven Jungheinrich® technology and AC motors

Sealed components for reliability in dusty or damp environments

Smart performance options to enhance order picking productivity

Optional RFID technology for precise aisle recognition



EKS 314

High-level order picker (3,000 lbs.)

Offering high throughput performance, the EKS 314 high-level order picker sets new standards in ergonomic design, efficiency and performance.

With a load capacity of up to 3,000 lbs. and order picking heights up to 366", this truck is specifically designed for high pick rate and high density storage applications.

Available with 24- or 36-Volt power options, the EKS can be customized to match the specific needs of your business – from various operator platform widths and mast heights to multiple base leg and fork length configurations.

Take your order picking performance to the next level:

- **High energy efficiency** – Runs two shifts on one battery charge –The industry-exclusive Jungheinrich "2 Shifts, 1 Charge" program guarantees that the EKS 314 order picker will run for two full shifts on one battery charge – with no interim charging, no battery changing and no additional charging equipment needed.
- **Industry-leading ergonomics** allow for greater operator comfort and control. The stable control handle base and ultra-comfort cushioned floor provide added comfort, while the traveling curveCONTROL feature automatically reduces speed while turning corners for optimum control.
- **Exclusive Jungheinrich components**, including the drive and hydraulic motors, software and operator controls, have undergone extensive in-house and field testing for proven reliability and performance.

Smart options are available to help enhance order picking performance and reduce operational risk:

- **End of aisle control** – RFID Transponder Technology automatically slows the truck when approaching the end of a guided aisle. Truck behaviors can be customized for slowing, stopping and lift/lower cutoff when approaching tunnels, walkways or overhead obstructions.
- **Advanced Platform Visibility option** – allows operators to see directly underneath the operator platform by way of a monitor and attached camera to detect if any personnel or objects are in the vicinity of the truck before lowering.

 **JUNGHEINRICH**®

EKS 314

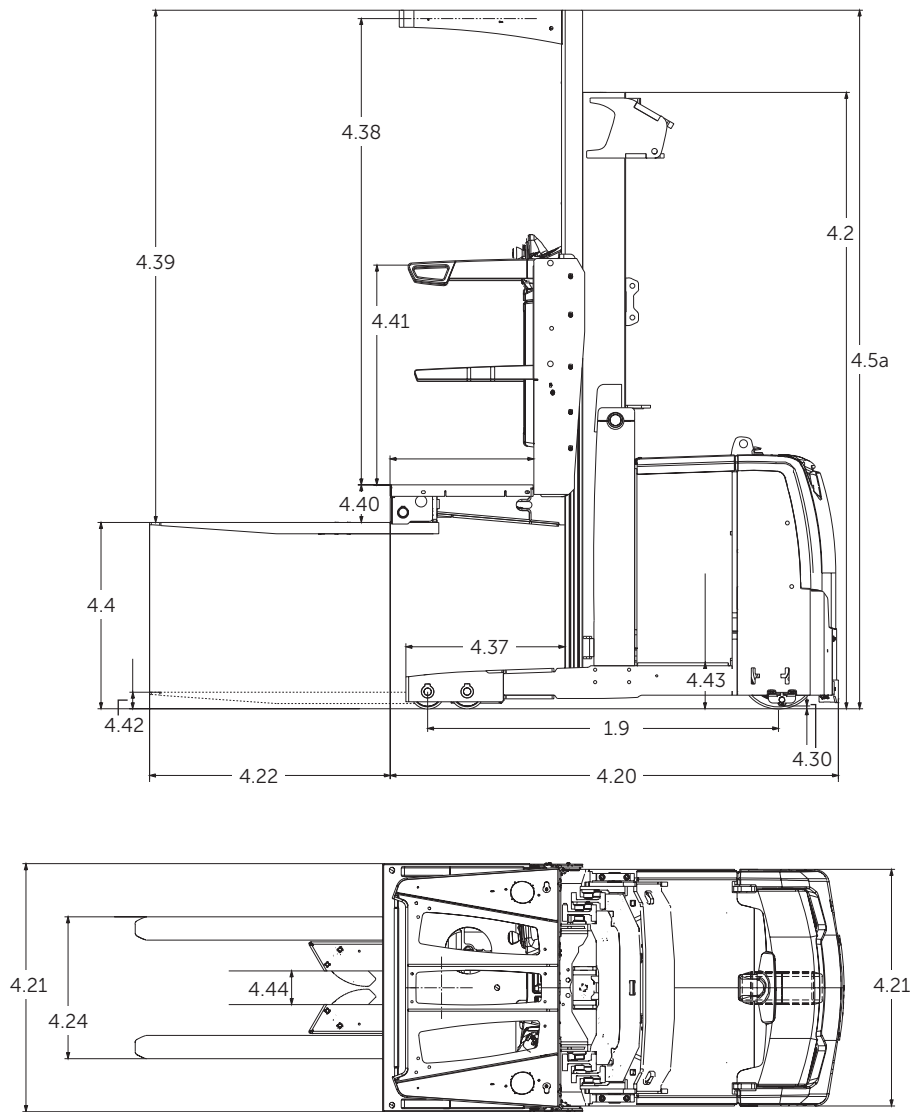

Mast Types									
	Maximum Fork Height		Overall Lowered Height		Full Free Height		Overall Extended Height		Notes
	MFH		OALH		FFH		OAEH		
	in	mm	in	mm	in	mm	in	mm	
Two-Stage Mast	138	3,505	92	2,337	3	76	227	5,768	
	148	3,759	96	2,438	3	76	237	6,022	
	168	4,267	107	2,718	3	76	257	6,530	
	190	4,826	118	2,997	3	76	279	7,089	
	212	5,385	135	3,429	3	76	301	7,648	
Three-Stage Mast	195	4,953	92	2,337	3	76	284	7,216	
	207	5,258	96	2,438	7	178	296	7,521	
	238	6,045	107	2,718	18	457	327	8,308	
	273	6,934	118	2,997	29	737	362	9,197	1
	294	7,468	127	3,226	38	965	383	9,731	1 2
	315	8,001	135	3,429	46	1,168	404	10,264	1 2
	335	8,509	143	3,632	54	1,372	424	10,772	1 2
	350	8,890	149	3,785	60	1,524	439	11,153	1 2
366	9,296	155	3,937	66	1,676	455	11,560	1 2	

1 Equipped with mast support braces

2 Requires minimum overall baseleg width. Consult your dealer for more information.

Technical data

as of: 06/2016

Characteristics	Manufacturer			Jungheinrich		Jungheinrich				
	Model			EKS 314 (Short Chassis)		EKS 314 (Long Chassis)				
1.3	Drive			electric		electric				
1.4	Type of operation			stand-on		stand-on				
1.5	Load capacity / rated load	Q	lb	T	3,000	1,360	3,000	1,360		
1.6	Load center distance	c	in	mm	24	600	24	600		
1.8	Load distance (load axle to fork face)	x	in	mm	6.5	165	6.5	165		
1.9	Wheelbase	y	in	mm	61.2	1,554	66.1	1,680		
Weights	Service weight			lb	kg	5,730	2,600	6,395	2,900	
	Service weight with maximum weight battery, no load			lb	kg	8,030	3,642	9,295	4,215	
	Service weight with minimum weight battery, no load			lb	kg	7,680	3,484	8,993	4,079	
	2.3	Axle loading, no load, front / rear		lb	kg	4,467 / 3,563	2,026 / 1,616	5,092 / 4,123	2,310 / 1,870	
	Axle loading with rated load, front / rear		lb	kg	2,778 / 8,270	1,260 / 3,751	3,461 / 8,800	1,570 / 3,992		
Wheels, Chassis	3.1 Tires			polyurethane		polyurethane				
	3.2	Tire size back (load) – based on 42" or 44" W baseleg ³⁾		in	mm	6 x 2.88	152 x 74	6 x 2.88	152 x 74	
	3.3	Tire size front (drive)		in	mm	13.5 x 5.5	343 x 140	13.5 x 5.5	343 x 140	
	3.5	Wheels, number, front / rear (x=drive wheels)			1x / 4		1x / 4			
	3.7	Tread width (center of tires) ¹⁾		in	mm	37.8	960	37.8	960	
Dimensions	4.2	Lowered mast height		in	mm	107	2,721	107	2,721	
	4.4	Maximum fork height ²⁾		in	mm	238	6,046	238	6,046	
	4.5a	Extended mast height (including platform) ²⁾		in	mm	327	8,310	327	8,310	
	4.7	Overhead guard height (top)		in	mm	92	2,337	92	2,337	
	4.8	Lowered platform height		in	mm	10	245	10	245	
		Maximum platform height		in	mm	248	6,291	248	6,291	
	4.19	Overall length (with 42" L forks installed)		in	mm	120	3,040	125	3,166	
	4.20	Length to fork face (includes fork thickness)		in	mm	78.0	1,980	83	2,100	
	4.21	Overall width – chassis / wheel legs		in	mm	40 / 42	1,016 / 1,067	40 / 42	1,016 / 1,067	
	4.22	Fork dimensions – length x width x thickness		in	mm	42 x 4 x 2	1,280 x 100 x 50	42 x 4 x 2	1,280 x 100 x 50	
	4.24	Fork carriage width ¹⁾		in	mm	30	762	30	762	
		Fork spacing – out-to-out minimum / maximum		in	mm	24 / 30	610 / 762	24 / 30	610 / 762	
	4.30	Ground clearance at lowest point		in	mm	0.45	12.0	0.45	12.0	
	4.32	Ground clearance at center of wheelbase		in	mm	1.9	47.2	1.9	47.2	
	4.35	Minimum outside turning radius		in	mm	71.2	1,808	76.2	1,935	
	4.37	Length to tip of wheel arms		in	mm	27.6	702	27.6	702	
	4.38	Inside operator compartment height		in	mm	81.1	2,060	81.1	2,060	
	4.39	Top of fork to top of overhead guard		in	mm	89.0	2,263	89.0	2,263	
	4.40	Top of fork to floor height		in	mm	6.5	166	6.5	166	
	4.41	Operator compartment floor to side gate arm		in	mm	38.3	972	38.3	972	
4.42	Ground to top of fork when fully lowered		in	mm	3.0	75	3.0	75		
4.43	Ground to top of battery rollers		in	mm	8.0	203	8.0	203		
4.44	Pallet clamp opening width		in	mm	5.7	145	5.7	145		
Performance	5.1	Travel speed, loaded / no load		mph	km/h	7.5 / 7.5	12 / 12	7.5 / 7.5	12 / 12	
	5.2	Lift speed, loaded / no load		fpm	m/s	67 / 77	0.35 / 0.39	69 / 77	0.35 / 0.39	
	5.3	Lowering speed, loaded / no load		fpm	m/s	93 / 81	0.47 / 0.41	93 / 81	0.47 / 0.41	
	5.10	Brakes – service			regenerative		regenerative			
		Brakes – parking			electric spring-loaded		electric spring-loaded			
Electrical	6.1	Drive motor rating S ₂ 60 min.		HP	kW	9.3	6.9	9.3	6.9	
	6.2	Lift motor rating at S ₃ 15%		HP	kW	16	12	16	12	
		Battery compartment size		L	in	mm	38.4	975	38.4	975
				W			16.25	413	21.25	539
				H			32.49	825	32.49	825
		Truck voltage			Volts		24 / 36		24 / 36	
		Battery weight, minimum / maximum			lb	kg	1,950 / 2,300	885 / 1,043	1,950 / 2,300	885 / 1,043
Other	8.1a	Controls – drive / hydraulic			AC		AC			

1) Based on standard (common) configuration of truck with 42" baselegs.

2) Based on common mast configuration of 238" MFH

3) For baselegs wider than 44", wheel size is 6" x 4" (152 x 99 mm)

4) Based on common 16.25" battery compartment

Note: Equipping this model (these models) with a power source (e.g. Lithium-ion, Hydrogen Fuel cell, etc.) that has not been previously approved by the factory is considered a modification. Per OSHA 1910.178 and ANSI/ITSDF B56.1, please consult with your factory representative prior to installing any non-OEM power source that has not been previously approved.

This specification sheet only provides technical values for the standard truck. Non-standard tires, different masts, additional equipment, etc. could produce other values. Rights reserved for technical changes and improvements.

The Jungheinrich Advantage



Optimum control

Advanced ergonomics

The EKS 314 is equipped with the latest in ergonomic features to help ensure your operators work comfortably and confidently:

- Newly-designed operator platform – the ultra-comfort cushioned floor helps to isolate the operator's feet and legs during order picking and driving, providing enhanced stability.
- Stable control handle base – solid so that an operator can grip it securely during travel, yet retain precise control of travel and lifting functions. The angle and height of the control handle base is engineered for maximum operator comfort and control, therefore helping to enhance operator on-the-job confidence.
- Full-color interactive display panel – shows key performance indicators and truck status information in an easy-to-read manner for increased awareness.
- Side gates – nested out of the way when in the up position, giving the operator maximum access when picking product.
- Portable tote storage system – gives operators the ability to easily carry their personal tools and items from the order picker to and from other work stations.
- Single or dual USB port (optional) – provides 5-Volt / 2 Ampere power for electronic devices.
- LED lights (optional) – for increased awareness and visibility in the warehouse.
- Dual fans (optional) – for optimum operator comfort.

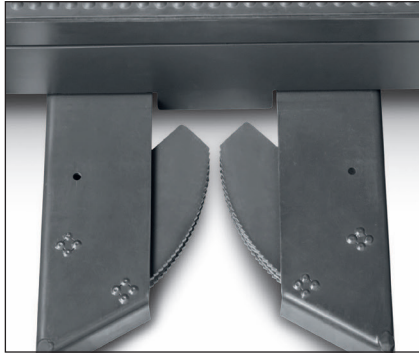

Textured tooth pallet grip

Key productivity and efficiency features

- Jungheinrich curveCONTROL – automatically reduces speed while turning corners.
- Electric steering – reduces the effort required to control the truck, leading to increased productivity.
- Automatic pallet grip – unidirectional textured tooth edge holds the pallet center runner, automatically centering the pallet for a secure grip.

Run longer with higher performance

60+ years of design experience has gone into the making of Jungheinrich warehouse products – with more than 400,000 Jungheinrich-built trucks in use worldwide. This extensive experience and expertise is incorporated into the EKS 314 motor technology, delivering:

- High overall performance
- Guaranteed to run 16 hours on one battery charge
- Smooth, rapid acceleration during travel, lifting and lowering
- Low power consumption
- Effective thermal management
- Reduced wear on components
- Reduced maintenance due to 1,000-hour service intervals

Customized for your business

Optimize the EKS for your warehouse and operator preference:

- 24- or 36-Volt power
- Four battery compartment options: 14.25", 16.25", 18.25" and 21.25"
- Five simplex masts from 138" to 212", and nine triplex masts from 195" to 366"
- Seven base leg sizes from 42" to 62" long
- Eleven fork lengths, 30" to 96", adjustable side-to-side

- Three wire or rail guidance options, including Aisle Transponder Technology for customized aisle performance and two-hand operation in aisle
- Wide range of operator platform widths (standard is 42")

Custom package options

- Freezer conditioning – includes display with integrated heater and wire mesh mast guard designed to withstand cold environments.
- Furniture picking option – includes various fork length options and a tether pole to allow operators to move across the platform (special order).
- Guidance options (wire and rail) – programmable smart truck performance features include travel speed and lift height control by way of an RFID aisle transponder.

Lithium-Ion Availability:

- Greater power efficiency
- Run for 24 hours a day, 7 days a week with opportunity charging
- Zero battery maintenance
- No watering
- No more battery exchanges
- No gas emissions, odor or acidification
- No special charging areas or equipment needed
- Longer lasting life cycles (up to 3,000)
- 5-year warranty on batteries
- 2-year warranty on chargers

Parts when you need them

Jungheinrich's Parts Fast or Parts Free Guarantee ensures next-business-day delivery by 5:00 PM of all Jungheinrich parts in the United States, or they're free, including freight. For customers in Canada and Mexico, the guarantee ensures shipping of parts within 24 hours from the time the order was placed by the dealer. See your local Jungheinrich dealer for program details.

- * Programs may be subject to change without notice and may vary by region. Please ask your local Jungheinrich dealer for complete terms and conditions.