

Synchronous reluctance motor converts energy into power and lowers energy consumption

Ergonomic and adjustable operating concept

Up to 25 percent more throughput with optional warehouseNAVIGATION

Excellent visibility in warehouse operation



EKS 412s / 414s

High-Level Order Picker (2,200 / 3,000 lbs.)

The powerful and efficient EKS 412s/414s medium/high-level order picker provides peak performance in narrow-aisle applications.

Equipped with an innovative, seamless simplex 3-stage mast, the EKS 412s/414s offers the tallest height among all vertical order pickers on the market reaching picking heights of over 45 feet and a 25 percent faster lift speed over the previous generation.

Longer Run Times:

Jungheinrich's energy efficiency class IE4 synchronous reluctance lift motor combined with 48-V control technology increases efficiency while reducing energy loss maintaining the advantages of three-phase AC motors.

The new technology helps reduce energy loss by almost 50 percent, translating into longer run times and greater performance.

How It Works:

- During operation, the motor converts around 93 percent of the energy into power.
- Rotor design emits no energy reducing heat.
- This lowers energy consumption and loss by about 50 percent, and significantly increases vehicle performance.

Smart Systems:

The EKS 412s/414s also comes equipped with several "smart" systems for greater operator control and productivity.

Jungheinrich's unique warehouseNAVIGATION (optional) system can also be added to further boost picking accuracy, increasing productivity by up to 25 percent and saving costs. Used in conjunction with RFID transponders placed inside the guided aisles, the truck detects its current position within the aisle and will automatically locate the next picking position according to the operators travel/lift command. This results in an up to 25 percent increase in productivity.

JUNGHEINRICH®

EKS 412s

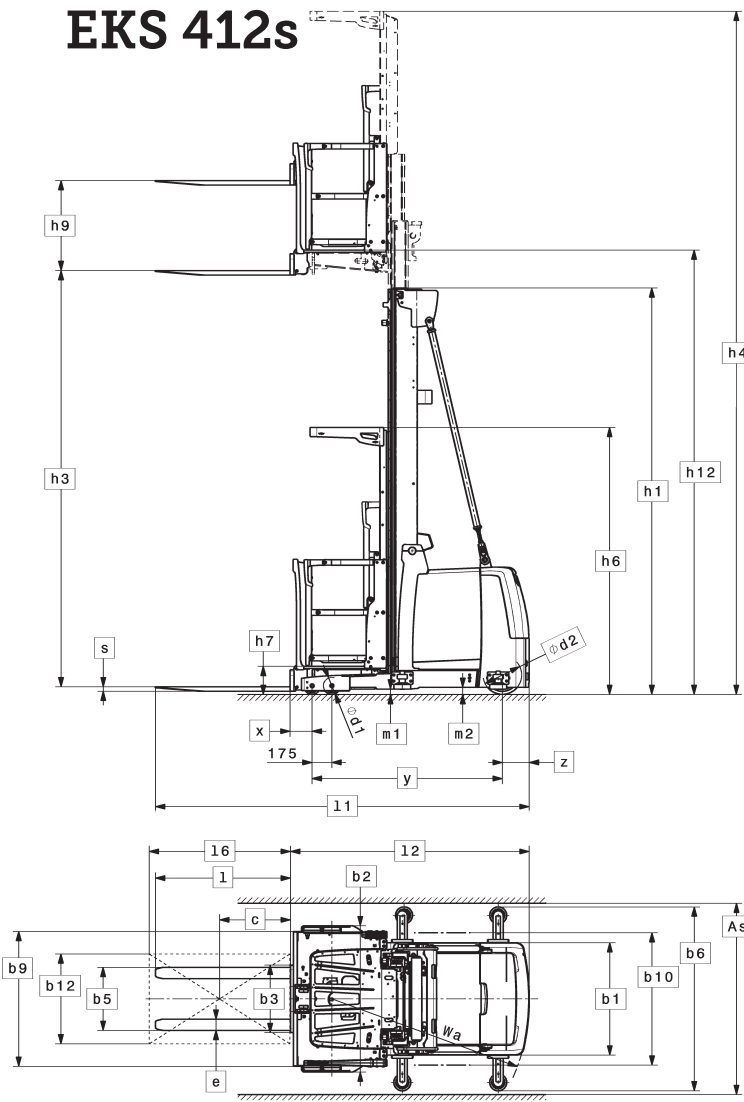

EKS 414s

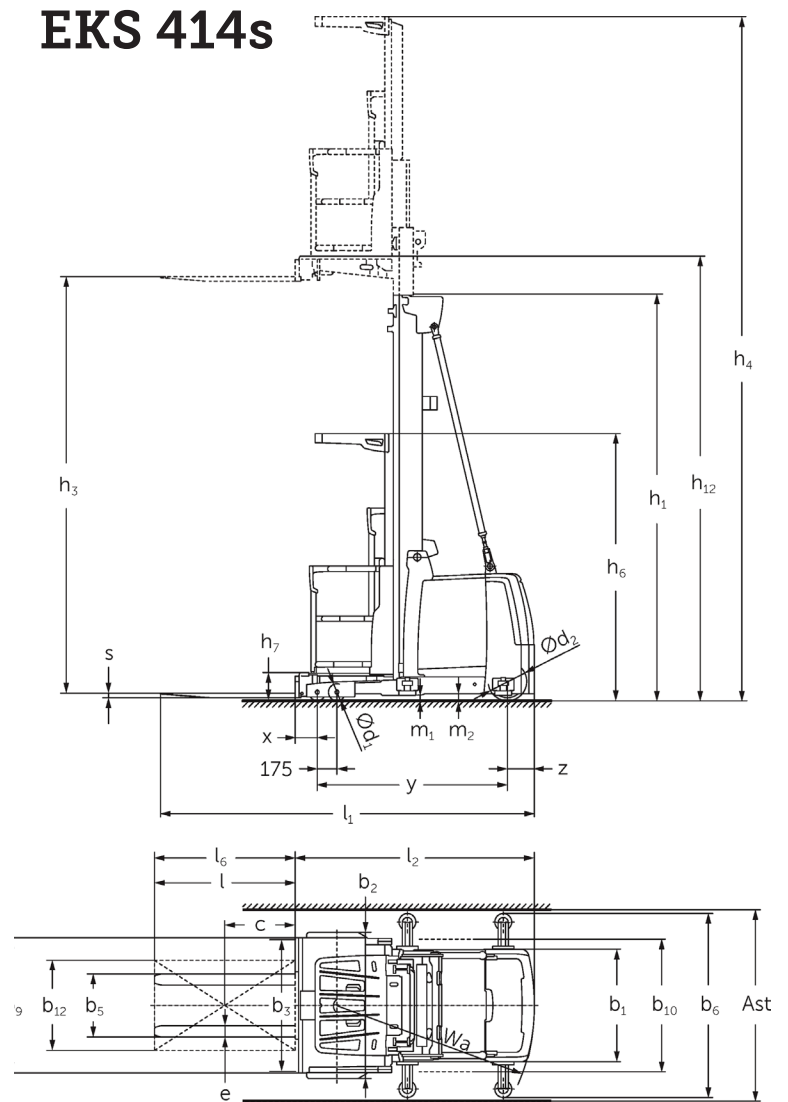

Mast Table

Designation	MFH		OALH		Extended Mast Height		Order Picking Height (Platform Height + 63")		FFH (Fork Height Before Mast Staging)	
	in	mm	in	mm	in	mm	in	mm	in	mm
Two-Stage Simplex Mast	167	4,250	116	2,950	261	6,620	238	6,045	3	75
	197	5,000	131	3,330	290	7,370	268	6,795	3	75
	217	5,500	142	3,600	310	7,870	287	7,295	3	75
	236	6,000	152	3,850	330	8,370	307	7,795	3	75
	256	6,500	163	4,125	349	8,870	327	8,295	3	75
	295	7,500	183	4,650	389	9,870	366	9,295	3	75
Three-Stage Simplex Mast	335	8,500	203	5,150	428	10,870	405	10,295	3	75
	217	5,500	103	2,610	310	7,870	287	7,295	3	75
	236	6,000	110	2,780	330	8,370	307	7,795	3	75
	256	6,500	116	2,940	349	8,870	327	8,295	3	75
	276	7,000	123	3,110	369	9,370	346	8,795	3	75
	295	7,500	129	3,275	389	9,870	366	9,295	3	75
	315	8,000	136	3,440	408	10,370	386	9,795	3	75
	335	8,500	142	3,610	428	10,870	405	10,295	3	75
	354	9,000	150	3,810	448	11,370	425	10,795	3	75
	374	9,500	157	3,980	467	11,870	445	11,295	3	75
Triplex Mast	413	10,500	174	4,410	507	12,870	484	12,295	3	75
	453	11,500	190	4,810	546	13,870	523	13,295	3	75
	492	12,500	205	5,210	585	14,870	563	14,295	3	75
	217	5,500	103	2,610	310	7,870	287	7,295	9	240
	236	6,000	110	2,780	330	8,370	307	7,795	16	410
	256	6,500	116	2,940	349	8,870	327	8,295	22	570
	276	7,000	123	3,110	369	9,370	346	8,795	29	740
	295	7,500	129	3,275	389	9,870	366	9,295	36	905
	315	8,000	136	3,440	408	10,370	386	9,795	42	1,070
	335	8,500	142	3,610	428	10,870	405	10,295	49	1,240
354	9,000	150	3,810	448	11,370	425	10,795	57	1,440	
374	9,500	157	3,980	467	11,870	445	11,295	63	1,610	
413	10,500	174	4,410	507	12,870	484	12,295	80	2,040	
453	11,500	190	4,810	546	13,870	523	13,295	96	2,440	
492	12,500	205	5,210	585	14,870	563	14,295	112	2,840	

*For EKS 412s with auxiliary mast, add 31.5 inches (800 mm)

Technical data

as of: 03/2020

			Jungheinrich		Jungheinrich				
			EKS 412s - 48 Volt		EKS 414s - 48 Volt				
Characteristics	1.1	Manufacturer		Jungheinrich		Jungheinrich			
	1.2	Manufacturer's type designation		EKS 412s - 48 Volt		EKS 414s - 48 Volt			
	1.3	Drive		stand-on		stand-on			
	1.4	Operator type		order picker - auxiliary mast		order picker - open platform			
	1.5	Load capacity / rated load	Q	lb	kg	2,200	1000	3,000	1,360
	1.6	Load center distance	c	in	mm	24	610	24	610
	1.8	Load distance, center of load axle to fork face	x	in	mm	6.1	155	5.7	145
	1.9	Wheelbase	y	in	mm	66.5	1690	66.5	1,690
	1.10	Center of drive wheel / counterweight	z	in	mm	9.4	240	9.4	240
	Weights	2.1	Net weight		lb	kg	8,047	3,650	7,429
2.2		Axle loading, loaded front / rear		lb	kg	7,397 / 2,679	3,575 / 1,160	7,397 / 2,679	3,355 / 1,215
2.3		Axle loading, unloaded front / rear		lb	kg	4,057 / 3,990	1,840 / 1,810	3,428 / 4,002	1,555 / 1,815
Wheels, Chassis	3.1	Tires		Polyurethane		Polyurethane			
	3.2	Tire size, load wheels	d ₁	in	mm	150 x 100			
	3.3	Tire size, drive tire	d ₂	in	mm	343 x 110			
	3.5	Number of tires: load wheels / drive tire		4 / 1		4 / 1			
	3.6	Tread width, load wheels		in	mm	34.5	876	34.5	876
	Dimensions	4.2	Mast height (lowered)	h ₁	in	mm	131.1	3,330	131.1
4.4		Fork height (see mast table)	h ₃	in	mm	196.9	5,000	196.9	5,000
4.5		Extended mast height (top edge overhead guard at cabin)	h ₄	in	mm	290.2	7,370	290.2	7,370
4.7		Height of overhead guard	h ₆	in	mm	93.3	2,370	93.3	2,370
4.8		Standing height lowered	h ₇	in	mm	9.6	245	9.6	245
4.14		Standing height raised	h ₁₂	in	mm	204.5	5,195	206.5	5,245
4.19.4		Total length including fork length	l ₁	in	mm	129.3	3,285	128.9	3,275
4.20		Length to face of forks	l ₂	in	mm	82.1	2,085	81.7	2,075
4.21		Overall width	b ₁ /b ₂	in	mm	39.4 / 39.4	1000 / 1000	39.4 / 39.4	1,000 / 1,000
4.22		Fork dimensions (H x W x L)	s / e / l	in	mm	1.5 / 3.9 / 47.2	40 / 100 / 1,200	2.0 / 3.9 / 47.2	50 / 100 / 1,200
4.24		Fork carriage width	b ₃	in	mm	37.8	960	38.2	970
4.25		Width across forks	b ₅	in	mm	33.4	849	24.8	630
4.27		Width across guide rollers	b ₆	in	mm	47.2	1,200	47.2	1,200
4.31		Floor clearance with load under mast	m ₁	in	mm	2.0	50	2.0	50
4.32		Ground clearance, center of wheelbase	m ₂	in	mm	2.4	60	2.4	60
4.33		Working aisle width for 48in x 42in pallet	Ast	in	mm	49.8	1,266	49.8	1,266
4.35		Turning radius (theoretical / maximum)	Wa	in	mm	72.6 / 76.0	1,845 / 1,930	72.6 / 76.0	1,845 / 1,930
4.39		Total lift (see mast table)	h ₃ + h ₉	in	mm	228.3	5,800	196.9	5,000
4.40		Order picking height	h ₁₂ + 1600mm	in	mm	267.5	6,795	267.5	6,795
4.42		Pallet width	b ₁₂	in	mm	40.0	1,016	40.0	1,016
4.43	Pallet length	l ₆	in	mm	48.0	1,219	48.0	1,219	
4.45	Inner clearance height of operator compartment		in	mm	82.7	2,100	82.7	2,100	
4.46	Outer width of operator compartment	b ₉	in	mm	39.4	1,000	39.4	1,000	
Performance	5.1	Driving speed, with load / without load		mph	km/h	7.5 ¹⁾	12.0 ²⁾	7.5 ¹⁾	12.0 ²⁾
	5.2	Lift speed, with load / without load		ft/min	m/s	78.7 ²⁾	0.4 ²⁾	78.7 ²⁾	0.4 ²⁾
	5.3	Lowering speed, with load / without load		ft/min	m/s	78.7 ²⁾ / 78.7	0.4 ²⁾ / 0.4	78.7 ²⁾ / 78.7	0.4 ²⁾ / 0.4
	5.10	Service brake				regenerative		regenerative	
	5.11	Parking brake				electric spring loaded		electric spring loaded	
Motors	6.1	Drive motor, output S2 60 min		kW	6.5		6.5		
	6.2	Lift motor, output at S3 15 %		kW	12		12		
	6.3	Battery compartment size		in	mm	37.2 x 21.3 x 30.9	945 x 540 x 784	37.2 x 21.3 x 30.9	945 x 540 x 784
		Battery Roller Height		in	mm	8.7	220	8.7	220
	6.4	Battery voltage / nominal capacity K _s		V	Ah	48 / 500		48 / 500	
	6.5	Minimum battery weight		lb	kg	2,022	917	2,022	917
Other Details	8.1	Type of drive control				AC drive control		AC drive control	
	8.4	Sound pressure level at operator's ear according to ANSI / ITSDF B56.1			dB (A)	70		70	
	8.6	Steering				electric		electric	

1) With drivePLUS Performance Package: Rail guided 7.5 mph (12.0 kph); Wire guided 6.5 mph (10.5 kph)

2) With liftPLUS Performance Package: EKS 412s 98.4 ft/min (0.50 m/s); EKS 414s 88.6 ft/min (0.45 m/s)

Note: Equipping this model (these models) with a power source (e.g. Lithium-ion, Hydrogen Fuel cell, etc.) that has not been previously approved by the factory is considered a modification. Per OSHA 1910.178 and ANSI/ITSDF B56.1, please consult with your factory representative prior to installing any non-OEM power source that has not been previously approved.

Non-standard tires, different masts, additional equipment, etc., could produce other values. Rights reserved for technical changes and improvements.

The Jungheinrich Advantage



Visibility to high loads



Simplified pallet retention on the EKS 414s



Ergonomic operator compartment

Performance

The versatile EKS 412s/414s enables maximum picking performance and efficiency, from the first racking level to heights over 45 feet tall.

Performance enhancing options:

- liftPLUS: Increase lift speed
- drivePLUS: Increase the travel speed
- positionCONTROL: semi-automated approach to lift height

Efficiency

Cost-effective energy management:

- Synchronous reluctance lift motor for optimal efficiency with minimum energy loss
- 48-V control concept: increases performance with a compact unit that contains fewer cables and plugs
- Area-specific speed profile with the use of transponders

Comfort and protection

Ergonomic Operators Compartment:

- Optimized operating concept
- Excellent all-round visibility
- Easy entry with low step up height
- Foldable side barriers
- Spacious cabin with ample storage
- Ergonomic floor mat and sizable operator presence pedal

Productivity

RFID technology (optional)

- Truck control with transponder technology
- Permanent distance measuring for exact positioning within the warehouse allows flexible and precise end of aisle slow down or stop
- Programmable lift/travel cut-outs
- Travel speeds optimized according to the floor topology

warehouseNAVIGATION (optional)

- Links the EKS 412s/414s to the warehouse management system (WMS) via radio data terminal or scanner
- Direct acceptance of the target destination in the narrow aisle on the truck display
- Semi-automatic vertical and horizontal positioning
- Improved order-picking performance with semi-automation
- Eliminate incorrect positioning through RFID intelligent technology

Service and maintenance

- Expansive dealer service network
- Integrated diagnostic system
- 1,000 operating hours planned maintenance intervals

Parts when you need them

Jungheinrich's Parts Fast or Parts Free Guarantee ensures next-business-day delivery by 5:00 PM of all Jungheinrich parts in the United States, or they're free, including freight. For customers in Canada and Mexico, the guarantee ensures shipping of parts within 24 hours from the time the order was placed by the dealer. See your local Jungheinrich dealer for program details.

- Programs may be subject to change without notice and may vary by region. Please ask your local Jungheinrich dealer for complete terms and conditions.

1-877-JH-FORKS

www.logisnextamericas.com/jungheinrich

The Jungheinrich logo features a red upward-pointing arrow above the word "JUNGHEINRICH" in a bold, black, sans-serif font.